

Chapter C

RingComm

Digital Network Adapter

DNA100

CHAPTER C

TABLE OF CONTENTS

<u>DNA100 DIGITAL NETWORK ADAPTER</u>	C5
INTRODUCTION	C5
INSTALLATION	C6
Network connections	C6
RS232 signals	C7
RS422 signals	C8
Setting Baud Rate / Selecting Device Type	C9
Communication Protocols	C9
Setting Network and Device Address	C10
External Alarm Output	C10
FRONT PANEL SWITCHES AND INDICATORS	C11
<u>MENU SYSTEM OPERATION</u>	C12
MAIN MENU	C12
MENU OPTIONS	C12
STATUS DISPLAY	C14
Description of Status	C15
Description of Status Headings	C15
Additional Status For Master Display Line	C16
Operation	C16
NETWORK MONITOR	C20
NETWORK INFORMATION	C22
PACKET MONITOR	C24
<u>ACTIVITY LOG PRINTER</u>	C26
Description of Status Headings	C26
Description of Status	C26
Additional Status For Devices	C27
<u>VIDEO SWITCHER</u>	C29
<u>INPUT / OUTPUT MODULE</u>	C30

DNA100 DIGITAL NETWORK ADAPTER

INTRODUCTION

The **Digital Network Adapter** (DNA100) interfaces an external RS232 or RS422 device to *Ring Communications'* Crisis Alert System. By setting DIP switches, the DNA100 can be selected to drive these devices:

Terminal:

The external device may be a VT100 Terminal or a PC with VT100 emulation software. The DNA100 is used to configure the following devices:

DXC901 Exchange controller for CB901

DXC910 Exchange controller for CB910/RM5K

DNA200 Video switcher

DNA300 Input Output Module

DNA400 Pocket page interface

A menu of options on the terminal also allow the user to set the Time/Date, List devices connected to the Crises Alert Network, View Errors on network, and Monitor network data traffic. The terminal may also be used as an annunciator display. (see MENU SYSTEM OPERATION).

Printer:

Provides an event activity log of all annunciation and event handling with time/date stamp (see ACTIVITY LOG PRINTER).

The DNA100 operates on +24 VDC (+12, -12 VDC). It can be powered from a spare fuse in the CB901 central exchange or can be powered locally by a separate 24 VDC regulated power supply.

The recommended cord is the BF640A to connect the DNA100 to the RJ45 network jack, KB171. Cords and jacks must be ordered separately.

INSTALLATION

Each DNA100 in a system can be individually powered from a fuse in the CB901 or a local power supply operating off 24V regulated DC.

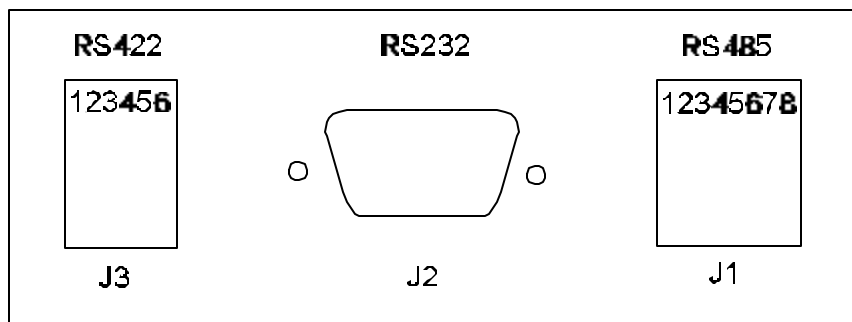

Figure C1 - Rear Panel Connectors

J1 - 8 pin (RJ45) Network connections :

Two modular jacks are provided at the rear of the DNA100. See **Figure C1**. **Use modular cables with straight through pin configuration only!** An 8-pin (RJ45) modular jack (KB171) and cord (BF640A) are required for connection to the network.

PIN# - DESIGNATION

- 1 - No connection.
- 2 - +12 VDC power input
- 3 - Data + (positive)
- 4 - No connection.
- 5 - No connection.
- 6 - Data - (negative)
- 7 - -12 VDC power input
- 8 - External Alarm.

The maximum total network length is 7000 feet. A unshielded twisted pair cable should be used for the data pair (24 or 22 AWG).

Connect the DATA pair from the network to pins 3 and 6 of the RJ45 wall jack maintaining polarity of the pair.

NOTE

If the Network is "live" take care NOT to short the data pair to the power pair. Touching the data leads to positive voltage, even for an instant, will result in damage to the RS485 drivers on devices already connected to the network.

If a remote power source is being used, the negative side of the supply must be referenced to Earth Ground, as well as, the CB901 power supply.

J2 - 9 pin (DB9) RS232 signals :

The DNA100 has a RS232 serial port interface, J2, that can connect to a terminal or printer. Check your terminal, printer or video switcher manual for the correct RS232 connector type, input, output and handshaking signal connections.

The maximum length for a RS232 cable connecting the DNA100 and other equipment is 50 feet.

A null-modem (LapLink) cable can be used to connect a DNA100 and a laptop or computer together if they are close enough to each other.

If you are going to make your own cable the following is a description of the pinout of the DB9 connector on the DNA100.

<u>J2</u> <u>PIN#</u>	<u>SIGNAL</u> <u>NAME</u>	<u>DIRECTION/</u> <u>DESIGNATION</u>
1	DCD	Data Carrier Detect, input.
2	RXD	Receive Data, input.
3	TXD	Transmit Data, output.
4	DTR	Data Terminal Ready, output.
5	GND	Signal Ground.
6	DSR	Not used.
7	RTS	Request to Send, output.
8	CTS	Clear to Send, input.
9	RI	Not used.

J3 - 6 pin (RJ11) RS422 signals :

A two twisted pair installation utilizing RS422 signals can be used to connect two bridges up to 7000 feet apart.

Use a six wire RJ11 cord with straight through wiring from J3 to another RJ11 jack on both sides of the installation, and then use two twisted pairs between the two RJ11 jacks as shown in **Figure C2**.

A strap **MUST** be installed between RTS and CTS of J2 (DB9), in order to disable flow control for the RS422. To do this, simply place a strap between pin 7 and pin 8 of J2. You could also solder this strap to a female DB9 connector with solder lugs on the rear, then insert it into the J2 connector. **Figure C2** illustrates the strapping of J2.

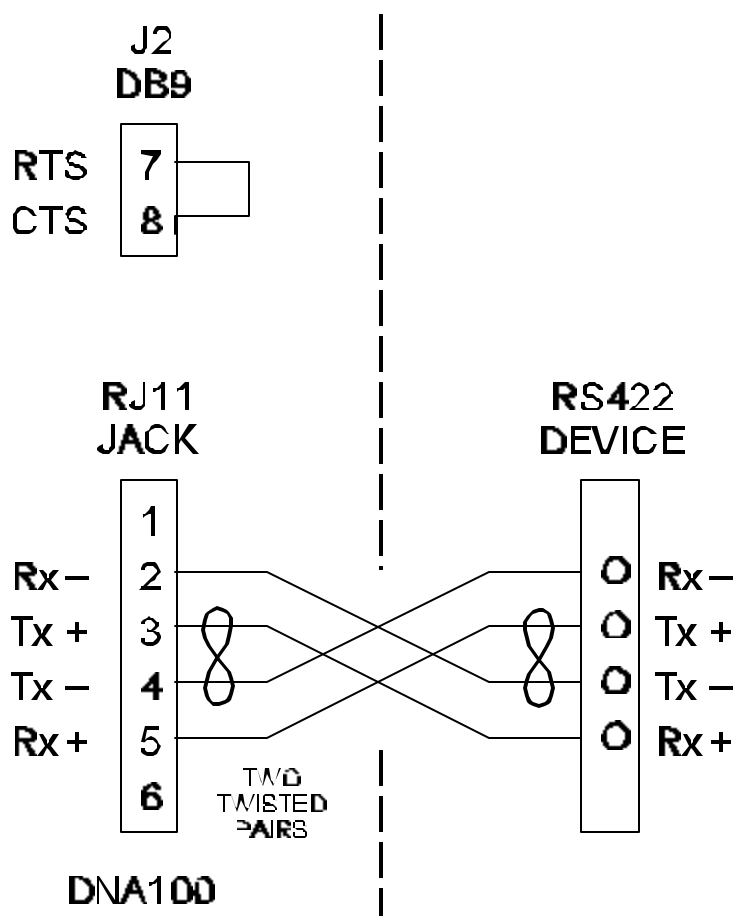

Figure C2 - RS422 Interconnection

Setting Baud Rate / Selecting Device Type (For switch locations see **Figure C3**.)

DIP switches SW3-1 through SW3-6 are used to set the desired baud rate for the RS232 device. SW3-7 and SW3-8 are used to select the RS232 device the DNA100 is driving (see chart below).

BAUD RATE	SW3						0 = off 1 = on	DEVICE	SW3	
	1	2	3	4	5	6			7	8
19200	1	0	0	0	0	1	Terminal	0	0	
9600	1	0	0	0	1	0	Printer	0	1	
4800	0	1	0	0	0	1	Not used	1	0	
2400	0	1	0	0	1	0	Not used	1	1	
1200	1	0	0	0	1	1				

Note! The Video switcher software is moved to DNA200
The I/O Module software is moved to DNA300

Communication Protocols

Aside from the baud rate, the terminal emulation should be set for VT100.
The DNA100 has No Parity, 8 Data Bits, and 1 Stop Bit.

Hardware flow control is used (RTS/CTS). The DNA100 will send data only if CTS is high from the other device.

Compatible emulation software:

Procomm Plus

Terminal for Windows 3.11

Hyper Terminal for Windows 95/98

Set software flow control to OFF and hardware flow control to ON.

Set Pace character to >

Setting Network and Device Address

DIP switch SW2 is used to set the address of the DNA100. See SETTING NETWORK ADDRESS of Chapter A - NETWORK for a full description for setting addresses, as well as, an addressing chart.

NOTE

If any DIP switches are changed while the DNA100 is operating, it must be RESET or powered off and then on, in order for the changes to become valid.

External Alarm Output

If an external signaling device is required in addition to the audible signal in the terminal device, a driver is available at the RJ45 jack. The driver can be directly connected to a small audible alarm signal such as the Sonalert 24 volt series. To connect a Sonalert, attach the positive wire from the Sonalert to pin 2 (positive supply) of the RJ45 jack and the negative wire from the Sonalert to pin 8 of the RJ45. Any time the terminal audible signal is activated the external alarm output pin will be connected to the negative supply activating the Sonalert.

If a load larger than 100 mA must be connected to the external alarm output such as a strobe light or mechanical bell, use the external alarm output driver to activate a 24 volt relay then connect the heavier load to the relay contact(s). A separate power pair must be used to power the external device to avoid a power drop in the DNA100 due to the surge of power from the external device.

FRONT PANEL SWITCHES AND INDICATORS - Figure C3**SWITCHES**

- SW1 - Reset. Creates a local reset for this node only.
- SW2 - Node & Network Address
- SW3 - RS232 Baud Rate, Device selection

L.E.D.'s (left side, network)

- RUN - Indicates the local processor in the DNA100 is running. Will illuminate after power up or reset.
- MASTER - Will light steady if this node is the master on the network. There can only be one master on each network. On power up, each device waits for a response from a master. If no response is received, then this device will take over as a master. Therefore, the first device powered up will be the master.
- TX - Transmit data to the Network. Will flash when the DNA100 sends data out on the Network. If the Master LED is on, the TX LED will flash constantly. When the Master LED is off, TX will only flash when transmitting to other devices.
- RX - Receive data from the Network. Will flash when data is transmitted from another device to the network. If the Master LED is on, the RX LED will flash when other devices respond to scanning from the Master. When the Master LED is off, the RX LED will flash constantly.

L.E.D.'s (right side, RS232)

- RTS - Request to send. Output, indicates the DNA100 is ready to receive data from the RS232 device.
- CTS - Clear to send. Input, (selectable for internal or external input) illuminated when the RS232 device is ready to receive data from the DNA100.
- TX - Transmit data. Output to RS232 device. Should flash every second when the time is updated or data is transmitted to the RS232 device.
- RX - Receive data. Input from RS232 device. Will flash when keys are pressed on the terminal device or data is sent to the DNA100.

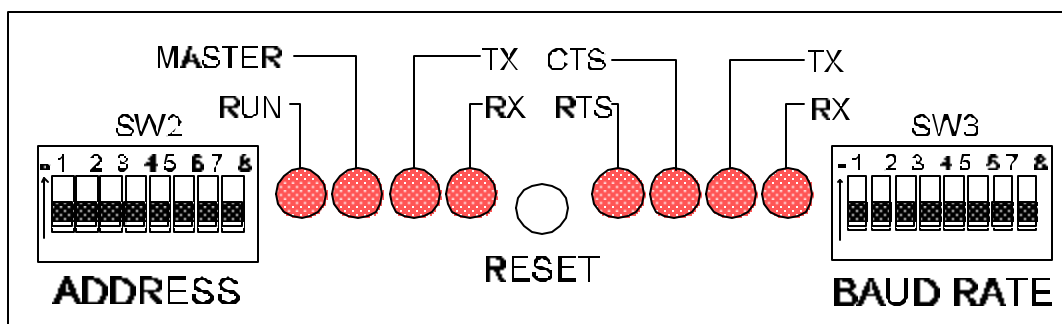
**Figure C3 - Front panel indicators**

MENU SYSTEM OPERATION

```
2000/09/22          RING CRISIS ALERT SYSTEM          14:57:42
=====
1- STATUS DISPLAY
2 - SET DATE/TIME
3 - CRT EMULATION
4 - NETWORK MONITOR
5 - NETWORK INFORMATION
6 - COMMUNICATIONS LINK
7 - CONFIGURE (DXC901/DXA100)
8 - BACKUP (DXC901/DXA100)
9 - RESTORE (DXC901/DXA100)
10 - MEMORY DISPLAY
11 - PACKET MONITOR
```

Figure C4 - Main Menu

MAIN MENU (?)

When a DNA100 is initialized, after power on or reset, the STATUS DISPLAY is brought up automatically (see STATUS DISPLAY option below). To access the MAIN MENU the user must press and hold the Control (CTRL) key and then press X on the terminal keyboard (CTRL-X).

The MAIN MENU displays the date and time on the top line and eight options. To choose an option from the MAIN MENU, move the highlighted line by using the **8** or **9** (UP or DOWN) arrows on the keyboard, or enter the number associated with the menu option required, highlighting your choice, and then press the enter key.

MENU OPTIONS:

1 - STATUS DISPLAY (See Figure C5 & Figure C6): Default power up screen. This option allows the user to view the real time status of all supervised stations and to receive and handle events. To go to the MAIN MENU from STATUS DISPLAY press and hold CTRL then press X.

2 - SET DATE/TIME : Select to set network date and/or time. The date format is YY/MM/DD and time is in 24 hour format, HH:MM:SS. Use the 7 and 6 (LEFT and RIGHT) arrows to place the cursor on the digits you wish to change, and press the 8 or 9 (UP or DOWN) arrows to increase or decrease the digits until the correct date and/or time is set. Pressing ESC will return you to the MAIN MENU.

3 - CRT EMULATION : To set emulation mode. Wyse 350 for color terminal, Wyse 50 for monochrome terminal or VT100 for PC emulation . Enter the number on the keyboard to select your choice. Press ESC to return to main menu.

4 - NETWORK MONITOR (See Figure C13): Displays all active nodes on all active networks including receive errors and retransmissions. Useful during installation and trouble shooting or basic network management. Press ESC to return to the MAIN MENU.

5 - NETWORK INFORMATION (See Figure C14): Displays all active nodes on all active networks including receive errors, retransmissions, software versions, and more for each node. Provides more useful information regarding each node in the system to aid in troubleshooting during installation or general network maintenance. Press ESC to return to the MAIN MENU.

6 - COMMUNICATION LINK: Allows communication with DXC910, DNA200, DNA300 and DNA400 (used for configuration).

7 - CONFIGURATION (DXC901/DXA100) : Allows for configuratio of DXC901/DXA100.

8 - BACKUP (DXC901/DXA100) : Allows for backup of programmed data in the DXC901/DXA100.

9 - RESTORE (DXC901/DXA100) : Used for uploading data saved during BACKUP in DXC901/DXA100

10 - MEMORY DISPLAY : Used to view memory locations of any node on the system. Useful for technicians to view error counters and for system software debugging. You will be prompted for Network Address and starting Memory Address. Once entered the next 64 memory locations are displayed. If the DNA100 Network Address presently being used by your terminal is inserted, the next 128 memory locations are displayed instead. Press ESC to return to the MAIN MENU.

11 - PACKET MONITOR (See Figure C15): For use by technical support staff **ONLY** for monitoring all network traffic, polling and responses for all node addresses for a specific network address. Press ESC to return to the MAIN MENU.

1- STATUS DISPLAY (See **Figure C5** & **Figure C6**)

The upper half of the STATUS DISPLAY shows the status of up to 50 supervised subscriber positions simultaneously. When a system has more than 50 supervised subscribers the 7 and 6 (LEFT and RIGHT) arrows are used to scroll the screen left and right one column at a time. The bottom half of the screen, used for event handling, does not move. The upper half of the display will view the 50 subscribers in five columns of 10 rows. The station dial numbers will be on the left-hand side of each column while it's status (OK, CALL, FAULT, BUSY, etc.) will be on the right-hand side. **Figure C6** shows an example of a status display with different statuses for 10 different stations in the left-most column. All stations will be displayed in ascending numerical order starting from the left, working down the column, and then moving to the next column to the right, etc. Unused areas of the upper display area will show ellipses (...) in place of station numbers and statuses.

If the DXC901, SUBSCRIBER ADDRESS \$FF, is programmed as a SUBSCRIBER TYPE 1, with a text description and a dial number code, the number will be displayed in the first column on the left. All reset activity from this stage then can be printed to the defined printer. This is useful when a system is installed with many networks and/or stages. **Figure C5** & **Figure C6** show what the DXC901 status would look like on the STATUS DISPLAY. It is the "01 OK" on the top line of the leftmost column. **Figure C12** shows what the NETWORK CONFIGURATION should look like to get this result on the STATUS DISPLAY. (See NETWORK CONFIGURATION - SUBSCRIBER ADDRESS later in this chapter for more details).

The lower half of the status display screen indicates status of five incoming annunciated events. If more than five annunciated events are in queue (QUE), use the 8 and 9 (UP and DOWN) arrows to scroll to your choice. There is room in the queue for up to 60 annunciated events.

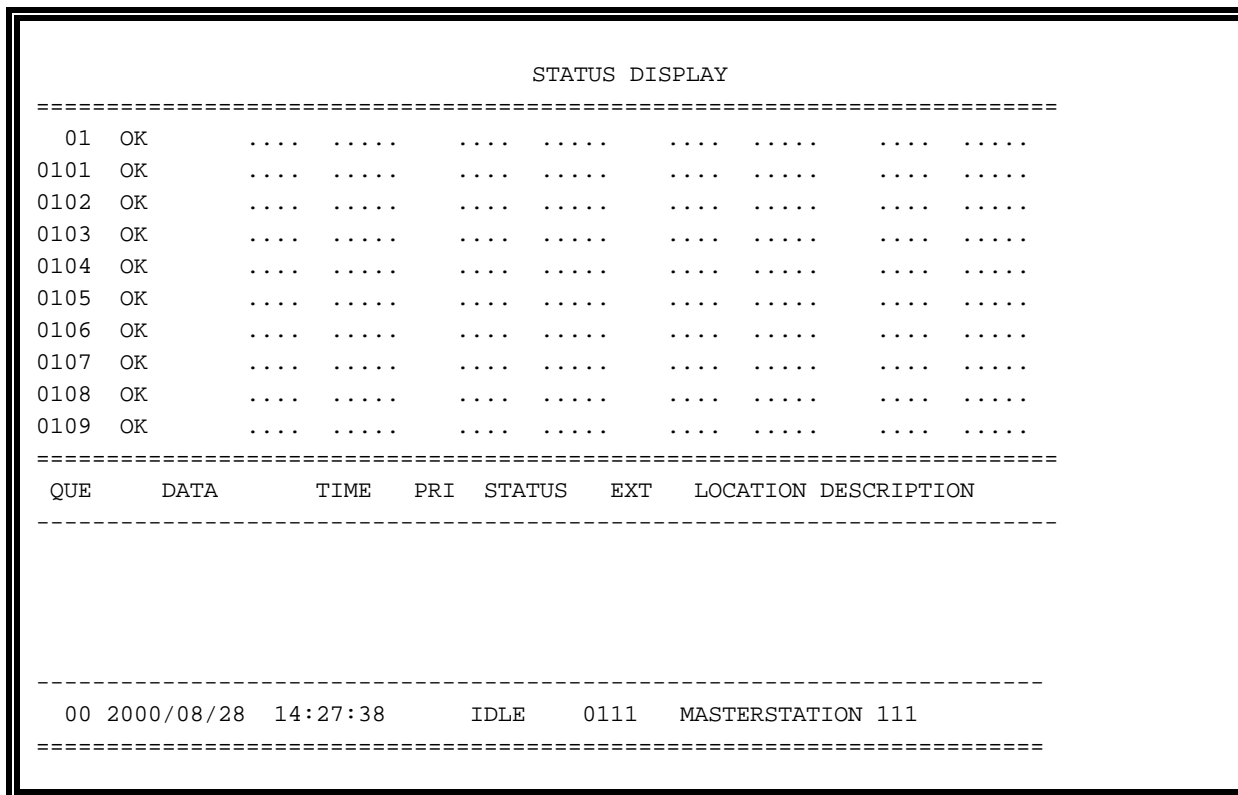

Figure C5 - Status Display, Idle

Description of Status :

OK	-	Supervised station in idle.
CALL	-	Incoming event in queue, designated as CALL by annunciating device.
ALARM	-	Incoming event in queue, designated as ALARM by annunciating device.
TALK	-	In conversation with this DNA100's master station.
FAULT	-	Incoming event indicating a hardware problem at/to that location.
PARK	-	An event placed on hold.
BUSY	-	Another Display is handling this call.
PWRFAIL	-	Power failure in a device (CB901 lost power and is running on batteries).
ACKNOWL	-	Non voice event has been acknowledged (such as PWRFAIL).

Description of Status Headings :

QUE	-	Actual numbered position in the queue for incoming events.
DATE/TIME	-	The date and time the event was detected.
PRI	-	Priority level of incoming event (1 - 9; 1 - highest, 9 - lowest).
STATUS	-	Status of each line (CALL, FAULT, TALK, PARK, BUSY, ALARM).
EXT	-	The dial number of the calling station.
LOCATION DESCRIPTION	-	Text description of calling location. Created during NETWORK CONFIGURATION.

The bottom line of the STATUS DISPLAY is the status for the master station for this DNA100's display.

QUE	-	The total number of events in queue
DATE/TIME	-	The present date and time (updated every second)
STATUS	-	Status of the Master station. (IDLE, TALK, WAIT, DIAL)
EXT	-	Dial number of the Master station
LOCATION DESCRIPTION	-	Text description of this Master station. Created during NETWORK CONFIGURATION.

Additional Status For Master Display Line :

- IDLE - Indicates no DNA100 activity present at the master station.
- DIAL - Indicates the DNA100 sent a request to dial. It sends a request to dial when an attempt is made to answer an incoming event.
- WAIT - Indicates status change for master. No keyboard entries will be accepted during WAIT state. WAIT status occurs after the master cancels an event that was handled.
- TALK - Master station is in conversation initiated by the DNA100. The DNA100 must be used to cancel the conversation to remove the TALK status from the display line.

Operation :**IDLE -**

When there are no annunciations (ALARMS, FAULTS or CALLS) to display, QUE will display 00, the TIME will always be visible and the event display lines will be off. The real-time status display will show all stations programmed to report to this annunciator as OK unless FAULTS are present in the system. In IDLE mode the Intercom master station assigned to the CRT will also be idle and may be used in normal intercom mode by using the dial pad on that station. Unused slots on the screen are filled with ellipses (...dots....).

INCOMING EVENT -

When the CRT DISPLAY receives an event a display line will appear and an audible tone will be heard from the terminal. There is room to display five events in the queue. The middle line will be highlighted as the current line that can be activated. See HANDLING MULTIPLE INCOMING ANNUNCIATIONS later in this chapter. The QUE will show the number of display lines in use. The user should always note the status of the event (ALARM, CALL, FAULT, PARK) before responding since the incoming status of the line will not be apparent when answered. The event lines will be placed in queue in the order they are received if they all have equal priority. When an event with greater priority is received it is placed ahead of existing events with lower priority level. Priority (PRI) level is programmable from 1 through 9, 1 being top priority (see NETWORK CONFIGURATION for programming).

HANDLING AN EVENT - The SPACE BAR

Once the status has been observed, the current highlighted display line can be answered by pressing the SPACE BAR on the CRT keyboard. When the SPACE BAR is pressed, the audible annunciation tone will stop, and the DXC901 will connect the intercom master station at the CRT DISPLAY with the substation that initiated the event. A warning tone will sound at both stations, and you may begin speaking after the tone. The intercom will normally switch your voice hands free, although it may be necessary to use the 'T' button on the intercom station for simplex operation (push to talk) to overcome background noise at either location. The 'T' may also be used whenever you want to continue monitoring a station for information or security reasons.

PRIORITY OVERRIDE - Intercom Privilege Feature

The master station at the CRT DISPLAY should be programmed with the "Priority override" privilege by SVT. If a busy or privacy signal is encountered, you may then press the 0 (zero) key on the intercom to override the signal and obtain voice contact before the intercom times out (default is 15 seconds for time out). If the intercom times out, you must dial the EXTENSION number shown on the DISPLAY line manually on the intercom ignoring leading zeros, and then use the priority override privilege. All substations reporting to an annunciator may also be programmed with "Privacy Category, Never" through SVT to avoid having to use the Priority feature on a station that appears in privacy.

REMOTE CONTROL - The O key

This key is used for Door Lock Control of the connected Substation.

DXC901 sends DTMF digit 5 to Substation

DXC910 sends DTMF digit 5 to Substation

DXA100 sends out event REMCON

CANCEL A CONNECTION - The X key

When the intercom call is completed, press the X key on the CRT DISPLAY keyboard, this will cancel both the intercom connection and the current DISPLAY line.

NOTE

Do not use the 'X' on the intercom station to cancel a call placed by the DNA100. It will only drop the intercom call and not the display line. This will prevent the substation from initiating any events until the display line is cleared.

A FAULT will return within two seconds after being canceled if it is a solid fault. FAULTS can occur intermittently during the scanning of the system due to electrical interference or disturbance at, or near, the station or its cable. Each substation is scanned for faults 80 times per second. Hard faults can be removed from the system temporarily by setting their device type to 0 in NETWORK CONFIGURATION and then reprogramming when the fault is corrected.

PARK - The P key

PARK is used to temporarily hold events that you need to get back to after handling other events or obtaining information. Solid FAULTS can also be placed in PARK to silence the audible tone until the problem is corrected by a service person.

HANDLING MULTIPLE INCOMING EVENTS -

If the QUE indicator displays a number greater than five, you can use the 8 or 9 (UP or DOWN) arrow keys to view the additional events and decide which lines should be handled first based on location of event or PRIORITY level. If the scrolling feature is not used, events can be handled on a first in first out basis by starting at the current line. When each event is canceled each DISPLAY line will automatically move into the middle highlighted line, and the middle DISPLAY line will be used each time until all lines are handled.

SILENCING THE AUDIBLE ANNUNCIATOR TONE -

When an incoming event is received and cannot be handled immediately, the tone can be temporarily silenced by pressing the X key on the terminal keyboard. If any additional activity occurs, the audible annunciation tone will sound again.

The audible tone will also sound if another event is received while you are presently handling one. Two options are available to handle an event while in conversation: One is to complete the present event, press cancel, then proceed to handle the additional events. The second option is to place the present event in PARK, then answer the additional events to assess the priority of the event handling using Park or "X" (cancel) as needed.

STATUS DISPLAY							
QUE	DATA	TIME	PRI	STATUS	EXT	LOCATION	DESCRIPTION
01	OK
0101	OK
0102	FAULT
0103	BUSY
0104	OK
0105	TALK
0106	CALL
0107	FAULT
0108	CALL
0109	ALARM
01	2000/08/27	13:36:49	01	ALARM	0109	LEVEL C1	BUILDING 3
02	2000/08/27	13:34:22	04	CALL	0106	AREA Z -	ZONE 7/OUTSIDE
03	2000/08/27	13:36:05	04	TALK	0105	ROOM 6	BUILDING 6
04	2000/08/27	13:42:19	05	FAULT	0102	ROOM 3	BUILDING 6
05	2000/08/27	13:43:23	05	BUSY	0103	DOOR 5A	ZONE 2/INSIDE
07	2000/08/28	15:27:38		IDLE	0111	MASTERSTATION	111

Figure C6 - Status Display, Active

NIGHT TRANSFER MODE -

The DNA100 is placed in Night Transfer mode by placing the associated intercom station in privacy. Calls to this DNA100 will now be sent to the next Annunciator device in the Annunciator address chain (for the sub station) without the programmed delay. The delay is used in normal Day mode to delay calls before they transfer (Max delay 9.9 minutes). When the DNA100 is in transfer mode the time display will flash the word "TRANSFER" . Calls are still queued in the DNA100 but the beeper is silenced. The beeper will beep once every 60 seconds as a reminder that we are in transfer mode. The DNA100 may answer calls in the Queue while in transfer mode.

NETWORK MONITOR See Figure C13

The NETWORK MONITOR is activated by selecting option five on the MAIN MENU screen. The NETWORK MONITOR allows real time viewing of all networks and nodes presently operating in a Crisis System. This screen should be used by technical personnel to verify network operation during installation and trouble shooting. The NODES shown are as seen by the master of that network. FREE, RETR, and RXERR are master information as well. To return to the MAIN MENU at any time press ESC.

When a node number is displayed steady (not flashing on and off) and the error columns are zero and/or not incrementing then those nodes are 'on-line' and working. Node numbers that are flashing may also increase the RETR and RXERR counters and indicate a trouble on that network. This could be due to an internal failure in a node or a poor data connection in the network.

If the network has excessive traffic, the FREE pool of elements will become depleted. This could lead to loss of communication with this node or network. Excessive traffic can be caused by one defective node, poor quality or damaged data pairs.

2000/01/16		NETWORK MONITOR					15:47:25			
=====										
NET	NODES	FREE	RETR	RXERR	NET	NODES	FREE	RETR	RXERR	
00	_____	00	00	00	16	_____	00	00	00	
01	76_4_2_0	27	00	00	17	_____	00	00	00	
02	_____2_0	27	00	00	18	_____	00	00	00	
03	_____	00	00	00	19	_____	00	00	00	
04	_____	00	00	00	20	_____	00	00	00	
05	_____	00	00	00	21	_____	00	00	00	
06	_____	00	00	00	22	_____	00	00	00	
07	_____	00	00	00	23	_____	00	00	00	
08	_____	00	00	00	24	_____	00	00	00	
09	_____	00	00	00	25	_____	00	00	00	
10	_____	00	00	00	26	_____	00	00	00	
11	_____	00	00	00	27	_____	00	00	00	
12	_____	00	00	00	28	_____	00	00	00	
13	_____	00	00	00	29	_____	00	00	00	
14	_____	00	00	00	30	_____	00	00	00	
15	_____	00	00	00	31	_____	00	00	00	

Figure C7 - Network Monitor

-
- NET - Network number. Networks 01-30 are for standard nodes, 00 is not used, and 31 is reserved for a DIGITAL EXCHANGE MASTER bridge.
- NODES - Node number. The master of that network is receiving messages from the nodes displayed. Node numbers are from 0-7 listed from right to left.
- FREE - The number of free queue elements for transmission. In each node, there is a free pool of message locations that can contain queued up messages generated for the node's internal housekeeping. When queued messages are handled, the queue element is placed back into the pool. This number is the remaining queue elements that can be used by the master node. This number is usually HEX 28 but will decrease depending on data traffic.
- RETR - The number of retransmissions logged by the master of this network. To reset the counter the master must be reset. Some retransmissions may exist on a good network due to data disturbance when installing or removing a node, or if transmissions are sent to a node that is not present on the system.
- RXERR - Number of receive errors logged by the master of this network. To reset the counter the master must be reset.

NETWORK INFORMATION See Figure C14

NETWORK INFORMATION is activated by selecting option five on the MAIN MENU screen. This screen can be used if there is a question about how the network is operating or if you want to see details about individual nodes on the system. While NETWORK MONITOR shows information based on the master's point of view, NETWORK INFORMATION shows information from the individual node's point of view. The information here is based on each node as opposed to the entire network. It's very useful for finding that errant node or for general information about each node in the system. Each line represents one node in the system and displays information described on the next page.

Unlike NETWORK MONITOR, NETWORK INFORMATION is not a real time display. The information displayed is not updated while in NETWORK INFORMATION, to update the information you must exit and then re-enter.

To exit and return to the MAIN MENU at any time, press ESC.

```
2000/11/02      Network information      15:47:25
=====
ADDR NET NODE   TYPE      VERSION   FREE  RETR  RXERR  HOURS
-----
 08  01  0   DXC901   1999/06/02  25   00   00   0007
 0A  01  2   DNA100   1999/03/04  25   00   00   0007
 0C  01  4   DAD104   1999/04/09  25   00   00   0007
 0E  01  6   DNA100   1999/03/04  25   00   00   0000
 0F  01  7   DNA100   1999/03/04  25   00   00   0007
 10  02  0   *****
 12  02  2   DAD104   1999/04/09  25   00   00   009A
```

Figure C8 - Network Information

- ADDR - Network address. The network address of the node on that display line.
- NET - Network number. The network the device on the display line is a member of.
- NODE - Node number. The node number of the device on the display line.

NOTE

REMEMBER -- Address, Net, and Node are related to each other. The Address is a combination of Net and Node. (See SETTING NETWORK ADDRESS of Chapter A - NETWORK for full explanation.)

- TYPE - Type of device. The device type (DXC901, DNA100, DAD104, etc.) of the node on that display line.
- VERSION - Version date. The version date of the device on this display line. The date is in the format of YYYY/MM/DD (year, month, day). To be compatible with the NETWORK INFORMATION screen the version date of the firmware has to be dated 960105 or later. If the firmware in the device is older, it will display asterisks (***) in place of TYPE and nothing else to the right of TYPE for that display line.
- FREE - The number of free queue elements for transmission. In each node, there is a free pool of message locations that can contain queued up messages generated for the node's internal housekeeping. When queued messages are handled, the queue element is placed back into the pool. This number is the remaining queue elements that can be used by the device on this display line. This number is usually HEX 28 but will decrease depending on data traffic.
- RETR - The actual number of retransmitted messages logged from the device on this display line. To reset the counter this device must be reset. Some retransmissions may exist on a good network due to data disturbance when installing or removing a node, or if transmissions are sent to a node that is not present on the system.
- RXERR - Number of receive errors logged by the device on this display line. To reset the counter the device on this display line must be reset.
- HOURS - Time since reset. Number of hours in hexadecimal format.

PACKET MONITOR

Option eight on the main menu is PACKET MONITOR. This feature allows a technical person to actually view the data packets on the network. This monitor is a powerful debugging tool used primarily for software development and testing although it also can be utilized for trouble shooting.

To exit and return to the MAIN MENU, press Esc. This will reset the DNA100.

An example of the packet monitor is shown in **Figure C15**.

```

A B C D E F G H I J
00 FF<0C UPDREQ 09 FF<01 0223 H I J
00 0E<08 RESET 30 01<00 0010 00 45 40 19 08 01 93 20 20 33 34 35 36 37 38 39
30
31 32 33 34 35 36 37 38 39 30 31 32 33 34 35 36 37 38 39 32 07A8
00 0C<08 TALK 30 01<07 0017 01 09 37 19 08 01 93 20 42 45 44 20 41 20 20 20
20
46 4C 4F 4F 52 20 35 20 20 20 20 20 20 20 20 20 20 20 20 06A0
00 0E<08 CALL 30 01<06 0016 01 52 40 19 08 01 93 20 44 4F 4F 52 20 35 20 54
48
49 52 44 20 46 4C 4E 4F 52 20 20 20 20 20 20 20 20 20 074F
00 0A<08 CALL 30 01<06 0016 01 52 40 19 08 01 93 20 44 4F 4F 52 20 35 20 54
48
49 52 44 20 46 4C 4E 4F 52 20 20 20 20 20 20 20 20 20 07F0

```

Figure C9 - PACKET MONITOR EXAMPLE

Each lettered item in the example indicated by an arrow is described on the following page. These descriptions are intended to assist field personnel to explain PACKET MONITOR listings to a *Ring Communications* technician. They are not intended for a complete understanding of the data packets on the network.

NOTE

Do not enter packet monitor from the main system's operational display. Use your spare DNA100/display using an individual node address.

A = Error counter. Maintains total number of errors on network. This number is stored in the network master and can be reset by resetting the network master. A secure network will have no errors but some are possible if nodes are installed or disconnected and cause data disturbance.

Possible errors are:

- checksum error
- network error
- receiver overrun error
- noise error
- framing error
- number of retransmits

B = Transmit to node. In this example FF indicates a broadcast to all nodes. Other numbers indicate a node address.

C = Transmit from node. The example shows node 0C sending to FF (broadcast).

D = Event definition CALL, CONNECT, CLEAR, PARK, TALK, BUSY, etc.

E = Total number of bytes in this packet, 09.

F = Device to/from. The node may represent a device such as a master station. The example shows device 01 (line equipment 01 is the second subscriber port in the CB901) sending to FF (broadcast)

G = Checksum. The total of all data in the packet. This is recalculated when received and checked for accuracy. If the calculated checksum does not match the received checksum then a request to retransmit the packet occurs.

H = Time. Time is transmitted by the network master as a broadcast and the time may also be part of a packet indicating when an event occurred. The format is SS:MM:HH (45:40:19).

I = Date. Date is transmitted by the network master as a broadcast and the date may also be part of a packet indicating when an event occurred. The format is DD:MM:YY (08:01:93).

J = ASCII text field. The 30 character description for this device.

ACTIVITY LOG PRINTER

A serial RS232C printer can be attached to a DNA100 to provide a complete activity log of system. All stations to be logged must have the printer defined in their **SAR**. The DNA100 must be configured to drive a printer by setting SW3-7 off and SW3-8 on. The printer must have a RS232C serial interface. The standard print format is 80 columns, 66 lines per page.

Figure C16 shows a sample printed page of the Crisis Alert Activity Log Printer.

Description of Status Headings :

DATE	The DATE this page was printed. If the date changes before the page is full a new page is printed with events for the new date.
TIME	The actual time the event on each line occurred.
PRI	PRIORITY of the incoming event.
STATUS	Status of each event (CALL, FAULT, CONNECT, PARK, CANCEL, RESET, ALARM).
EXT	The dial number of the station generating the event.
LOCATION DESCRIPTION	Written description of the location or device stated under the EXT heading.
CONNECTED TO	Indicates the station connected to the device generating the event.

Description of Status :

CALL	CALL to annunciator. This only indicates a call condition was placed from type 1 sub station or type 3 sub-master station.
CONNECT	Indicates an event being handled in accordance with the annunciator display through Crisis Alert. (See HANDLING AN EVENT earlier in this Chapter or in Chapter D - DAD104)
FAULT	Indicates a hardware problem for the location printed and sent to the annunciator five seconds after the fault occurs. The time delay is due to a noise filter in the DXC901 that only records solid faults.
PARK	An event that was placed in PARK. A new CONNECT message will be generated when this event is retrieved again.
CANCEL	Indicates a disconnection of two devices that were previously connected. For example, a master station that presses the 'X' key on the terminal keyboard using a DNA100 will generate a CANCEL event.
ALARM	ALARM to annunciator. This indicates that an alarm condition was placed from a type 3 sub-master station.
PWRFAIL	The CB901 has detected loss of Power. It is now running on battery backup.
ACKNOWL	An event has been acknowledged by a DAD104 (such as PWRFAIL).
CLEAR	The Power has been restored to normal for the CB901 central exchange.

Additional Status For Devices :

RESET Indicates when a device has been RESET. This message is only printed if the device has a Printer Address defined during NETWORK CONFIGURATION. To enter a description for the DXC901 Digital Exchange Controller use Subscriber address \$FF and enter it as a SUBSCRIBER TYPE 0 station with the description needed. The dial number if inserted can be displayed on a CRT status display. Generally a two digit number is used to indicate a building or stage number in a multi stage configuration. Do not enter a priority or program channel for the DXC901.

ACTIVITY LOG FOR RING CRISIS ALERT SYSTEM					
DATE	TIME	PRI	TO	EVENT	FROM LOCATION
2000/08/24	15:59:50			RESET	Activity LOG Printer
2000/08/24	16:28:12	2	10	CALL	17 Elevator 4A
2000/08/24	16:28:23		17	CONNECT	10 Security
2000/08/24	16:28:48		17	CANCEL	10 Security
2000/08/24	17:32:45	5	10	CALL	28 Gate E
2000/08/24	17:33:16		28	CONNECT	10 Security
2000/08/24	17:35:03		28	PARK	10 Security
2000/08/24	17:35:05	1	11	CALL	10 Security
2000/08/24	17:35:08		10	CONNECT	11 Lobby
2000/08/24	17:35:22		10	CANCEL	11 Lobby
2000/08/24	17:35:28		28	CONNECT	11 Lobby
2000/08/24	17:36:56		28	CANCEL	11 Lobby

Figure C10 - Activity Log Print Example

VIDEO SWITCHER

This software has been moved to the DNA200.

INPUT / OUTPUT MODULE

This software has been moved to the DNA300.