

# ELMAX<sup>®</sup>

**alpha**  
COMMUNICATIONS

42 Central Drive  
Farmingdale, NY 11735-1202  
TOLL-FREE 1-800-666-4800

Phone (631) 777-5500 Fax: (631) 777-5599  
Email: info@alpha-comm.com  
Internet: http://www.alpha-comm.com

## POWER SUPPLY FOR "DIGIBUS" DOOR ENTRY SYSTEMS

### OPERATION MANUAL

## Art. 6941/C17

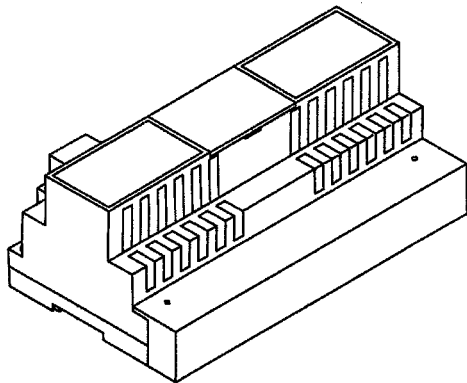

**Digi  
bus<sup>®</sup>**

UL product is according to UL 6500

Descrizione dei simboli contenuti nel trasformatore.  
doppio quadrato: l'alimentatore è Classe II;  
triangolo con fulmine: pericolo di scossa, tensione pericolosa;  
triangolo con punto esclamativo: pericolo, prestare attenzione.

Description of symbols shown in the transformer.  
double square: it is a class II power supply  
triangle with lightning: hazard of electric shock, dangerous  
voltage;  
Triangle with exclamation mark: danger, pay attention.



**CAUTION**  
RISK OF ELECTRIC SHOCK  
DO NOT OPEN

I circuiti interni dell'alimentatore sono protetti da un'ulteriore protezione FUSIBILI F 3,15 AL 250V.  
The circuits inside the power supply are further protected by a FUSE F 3.15 AL 250V.

### POWER SUPPLY INSTALLATION

The power supply must be installed in a dry place away from direct heat or dust. Ensure easy access for inspection and maintenance. Secure the unit to the wall with the anchor bolts provided or insert it into a rack with a omega DIN bar. Before connecting the unit use a tester to make sure that the cables are not broken or short-circuited. For user safety, the equipment operates at a low voltage and is separated from the mains by a high-insulation transformer. We recommend installation of an overload cutout of appropriate capacity between the mains and the unit. To complete the installation, proceed as follows:

- 1) Make the cabling connections to the terminal block in accordance with the diagrams enclosed with this manual.
  - 2) Connect up the power terminal block located beneath the rear cover.
  - 3) Power up the power supplier. Once correctly powered up, only the red "power-on" LED L6 for the entrance panel and interphones must be illuminated.
- The same rule also applies to all the other units in the system.

### GENERAL CABLE INSTALLATION INSTRUCTIONS

Correct DIGIBUS installation requires the following factors to be taken into account:

- the installation site
  - the size of the installation
- Nonetheless, for correct installation, the following precautions must be taken:
- the system cables must be layed taking into account the overall length of the system cabling; the cross-section of the cables increases with the overall length of the installation as shown in the tables given below.
  - the cables connecting the external/internal units and the power supply must not be run together with power cables (117V or greater), but must be installed in their own ducts.

### IMPORTANTI ISTRUZIONI PER LA SICUREZZA

- 1 - Leggere queste istruzioni
  - 2 - Conservare queste istruzioni
  - 3 - Prestare attenzione a tutte le avvertenze
  - 4 - Seguire le istruzioni
  - 5 - Non utilizzare quest'apparecchio vicino all'acqua
  - 6 - Pulire solamente con un panno asciutto
  - 7 - Non chiudere le aperture per la ventilazione. Installare l'apparecchio seguendo le istruzioni del costruttore.
  - 8 - Non installare l'apparecchio vicino a sorgenti di calore come radiatori, valvole di calore, stufe o altri apparecchi (incluso amplificatori) che producono calore.
  - 9 - Rispettare la polarizzazione o la messa a terra della spina. La spina polarizzata ha due lamelle, una pià larga dell'altra. La lamella larga o il terzo polo vengono forniti per la sicurezza. Se la spina fornita non va bene per la vostra presa, consultare un elettricista per la sostituzione della presa obsoleta.
  - 10 - Proteggere il cavo della tensione affinché non vi si cammini sopra o venga perforato, soprattutto in prossimità della spina, del contenitore, o dove esce dall'apparecchio.
  - 11 - Utilizzare solamente materiali per il montaggio/accessori specificati dal costruttore.
  - 12 - Per l'assistenza contattare personale specializzato. L'assistenza è necessaria quando l'apparecchio è stato comunque danneggiato, per esempio il cavo di alimentazione o la spina sono stati danneggiati, del liquido è stato versato od oggetti sono caduti nell'apparecchio, l'apparecchio è stato esposto alla pioggia o al vapore, non funziona normalmente od è caduto.
- AVVERTENZA:** Per ridurre il rischio di incendio o scariche elettriche, non esporre quest'apparecchio alla pioggia o al vapore.
- ATTENZIONE:** Queste istruzioni sono destinate solamente a personale qualificato. Per ridurre il rischio di scariche elettriche non effettuare alcuna assistenza diversa da quanto indicato nelle istruzioni per il funzionamento, a meno che non siate qualificati per fare ciò.

### IMPORTANT SAFETY INSTRUCTIONS

- 1- Read these instructions
  - 2- Keep these instructions
  - 3- Heed all warnings
  - 4- Follow all instructions
  - 5- Do not use this apparatus near water
  - 6- Clean only with dry cloth
  - 7- Do not block any ventilation openings. Install in accordance with the manufacturer's instructions.
  - 8- Do not install near any heat sources such as radiators, heat registers, stoves or other apparatus (including amplifiers) that produce heat.
  - 9- Do not defeat the safety purpose of the polarized or grounding-type plug. A polarized plug has two blades with one wider than the other. A grounding type plug has two blades and a third grounding prong. The wide blade or the third prong are provided for your safety. If the provided plug does not fit into your outlet, consult an electrician for replacement of the obsolete outlet.
  - 10- Protect the power cord from being walked on or pinched particularly at plugs, convenience receptacles, and the point where they exit from the apparatus.
  - 11- Only use attachments/accessories specified by the manufacturer.
  - 12- Refer all servicing to qualified service personnel. Servicing is required when the apparatus has been damaged in any way, such as power-supply cord or plug is damaged, liquid has been spilled or objects have fallen into the apparatus, the apparatus has been exposed to rain or moisture, does not operate normally, or has been dropped.
- WARNING:** To reduce the risk of fire or electric shock, do not expose this apparatus to rain or moisture.
- CAUTION:** These servicing instructions are for use by qualified service personnel only. To reduce the risk of electric shock do not perform any servicing other than that contained in the operating instructions unless you are qualified to do so.
- 13- Apparatus shall not be exposed to dripping or splashing and no objects with liquids, such as vases, shall be placed on the apparatus.

### MINIMAL CONDUCTOR SECTION (mm<sup>2</sup>)

Conductors	Ø up to 50 m.	Ø up to 100 m.	Ø up to 200 m.
4-5-9-10	0,75 mm <sup>2</sup>	1 mm <sup>2</sup>	1,5 mm <sup>2</sup>
lock	1 mm <sup>2</sup>	1,5 mm <sup>2</sup>	2,5 mm <sup>2</sup>
Others	0,5 mm <sup>2</sup>	0,75 mm <sup>2</sup>	1 mm <sup>2</sup>

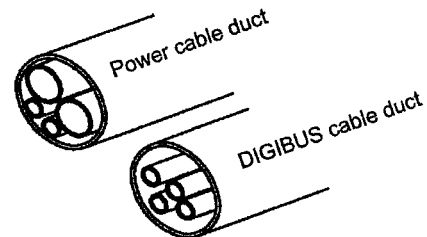

Conversion table of sections-diameters and relative resistances for 100 m. standard conductors.

Section mm <sup>2</sup>	0,12	0,25	0,35	0,50	0,75	1,00	1,50	2,50	4,00	6,00
Diameter mm.	0,40	0,58	0,68	0,80	1,00	1,15	1,40	1,80	2,30	2,80
AWG	26	23	22	20	18	16	14	12	10	
Decimal diameter	4/10	6/10		8/10	10/10	12/10	14/10	18/10		
Resistance Ω 100m.	14,00	6,60	4,80	3,50	2,20	1,70	1,14	0,69	0,39	0,28

### DIAGRAM SYMBOLS

	A.C. buzzer		Lamp		Loudspeaker		A.C. supply from mains
	A.C. bell		Push-button		Amplified microphone		Ground
	Electric lock		Switch		Receiver		Coaxial cable grip

#### TECHNICAL CHARACTERISTICS OF POWER SUPPLIER ART. 6941/C17

The basic power supply unit for all DIGIBUS electronic door opener systems, housed in a V-0 range technopolimeric case. Designed for mounting to equipment panels with DIN omega rails (12 modules).

Features inter-changeable cards and pull-out terminal blocks to facilitate rapid maintenance. The power supplier is fitted with an acoustic call generator and 6 LEDS indicating the operating status.

#### Main power supplier data:

- Dimensions: 208x135x72
- Power supplier weight:: 1,5Kg
- Power supply: 117V A.C. (+10/-10%) 60Hz  
(other power supplies are available on request)  
60VA
- Maximum absorbed power: 13,5VDC 1A intermitent: 90 sec. ON, 90 sec. OFF  
(maximum of 50 distributors Art. 949B and one entrance panel, or 200 appliances type Art. 6204 or 887B and one entrance panel).
- Low voltage supply: 15V rettificati 0,4A continuous duty  
(maximum of 3 x 24V, 3W lamps)
- Panel illumination output: 15V rectified 1A intermittent, 30 sec. ON, 150 sec. OFF
- Lock output:: 12VDC 0,15A intermittent, 255 sec. ON, 255 sec. OFF  
(maximum of 1 relay type 170/001, etc.).
- Outputs for activation of additional functions:

#### Built-in protection features:

- Transformer primary: PTC tipo SIEMENS C830
- 1st secondary, driving internal electronic circuits: F 3,15A 250V (F1) Fuse
- Secondary transformer winding supplying door lock and/or lamps: F 3,15A 250V (F1) Fuse
- Generator of electronic call: F 3,15A 250V (F2) Fuse
- Electronic interphone riser or panel short-circuit or overload cutout

#### LED status indicator unit:

- L1 - Lock power supply (15 and S1 terminals) YELLOW LED
- L2 - Door lock command (terminal S) YELLOW LED
- L3 - Auxilliary function 1 (terminal F1) GREEN LED
- L4 - Auxilliary function 2 (terminal F2) YELLOW LED
- L5 - Phonic line and call generator ((terminal3) GREEN LED
- L6 - Digital circuit power supply (terminals 4 and 5) RED LED

#### Description of power supplier terminal functions:

- |    |   |  |
|----|---|--|
| CH | Call signal activation control line.          | <i>This terminal is used by the entrance panels or switchboard to activate the call generator in the power supplier. When terminal CH is shorted to terminal 4, the call signal is activated by terminal 3. The signal remains active for the time terminal CH is short-circuited.</i>   |
| S  | Door lock release control line.               | <i>This terminal is used by the entrance panels or switchboard to release the door lock for the corresponding entrance panel or switchboard. When terminal S is shorted to terminal 4, terminal S1 is shorted to terminal 0 (15V rectified) and LEDS L1 and L2 illuminate. Terminal S1 remains shorted for the time terminal S is activated.</i> |
| F1 | Auxiliary function 1 activation control line. | <i>This terminal is used by the entrance panels or switchboard to activate function F1. When terminal F1 is shorted to terminal 4, the voltage at terminal R1 increases to 12 Vdc and remains at this voltage for the time terminal F1 is shorted. Activation of the function is signalled by illumination of LED L3.</i>                        |
| F2 | Auxiliary function 2 activation control line. | <i>This terminal is used by the entrance panels or switchboard to activate function F2. When terminal F2 is shorted to terminal 4, the voltage at terminal R2 increases to 12 Vdc and remains at this voltage for the time terminal F2 is shorted. Activation of the function is signalled by illumination of LED L4.</i>                        |

3	Phonic and call signal line.	<i>This terminal routes the call signal along the cable riser and signals the presence of units with the handset raised (engaged). When terminal CH is activated, a modulated call signal is transmitted by terminal 3 and LED L5 illuminates. When terminal CH is de-activated, the line connected to terminal 3 indicates the presence of one or more interphones with the handset raised (engaged) by illumination of LED L5.</i>
4	Digital circuit power line (negative).	
5	Digital circuit power line (+ 13.5 Vdc 1.5A).	<i>Energisation of terminal 5 is indicated by illumination of LED L6.</i>
4	Auxiliary function power line (negative).	
R1	Auxiliary function 1 power line (+ 12 Vdc 0.15 A).	<i>This terminal activates a relay when function F1 is activated. When terminal F1 is activated, terminal R1 is powered by a 12 Vdc voltage.</i>
4	Auxiliary function power line (negative).	
R2	Auxiliary function 2 power line (+ 12 Vdc 0.15 A).	<i>This terminal activates a relay when function F2 is activated. When terminal F2 is activated, terminal R2 is powered by a 12 Vdc voltage.</i>
S1	Door lock release line (1A).	<i>When terminal S is activated, terminal S1 is shorted to terminal 0 and LEDS L1 and L2 illuminate. The line is protected by a fuse F 3,15AL 250V (F2)</i>
15-0	15V (rectified) line: 0.4A continuous service; 1A door lock release.	<i>These terminals power the name card illumination lamps, door lock and services. The line is protected by a fuse F 3,15AL 250V (F2)</i>
PRIM	Power terminals: 117 Vac +10/-10% 60Hz.	<i>These terminals are mounted under the thermoplastic protection marked by the symbol  and are used to power the relay connections. No earth terminal is fitted, this being a power supplier constructed to Class 2 specifications.</i>

**PRELIMINARY OPERATIONS**

Following installation and connection of all the units in the system, power up the installation and make sure all the power suppliers effectively power up (indicated by illumination of the "power-on" LEDS on the power supplies themselves). On power suppliers Art. 6941/C17, 6942 and 6947, red LED L6 should illuminate only. Wait at least ten seconds after powering up the system before programming the units. You can then check and, if necessary, program the operating parameters of the entrance panels and/or switchboard. The entrance panels and switchboard are factory-set prior to delivery. The parameter settings must therefore be assessed and, if necessary, altered to accommodate specific system requirements. For further information about entrance panel and switchboard programming, refer to the instructions enclosed with the units. Once you have set the operating parameters for the entrance panels and switchboard, program the interphone user numbers. In the case of building complex installations, it is a good idea to program the user numbers by way of the stairway panels (secondary panels).

**PROGRAMMING INTERPHONE AND DIGITAL DISTRIBUTOR USER NUMBERS**

If the entrance panels are connected in parallel, disconnect those entry panels on which the ON-OFF jumper is disconnected (or set to OFF) before programming the user numbers (it is only necessary to disconnect the panels for programming). Entrance panels Art. 8943, 8945, 943/..., 943/5... can only be used to program the interphones after each entrance panel button has first been programmed. This done, program the individual units one at a time.

**Programming interphones with internal coder Art. 6204 and 887B from the entrance panel**

- 1) Briefly press the programming button on the interphone.
- 2) Press then the door lock release button until the LED near the programming button illuminates.
- 3) If the LED does not illuminate, repeat the above steps from point 1.
- 4) Remove the handset from the unit and check the audio connection with the entrance panel. Replace the handset.
- 5) From the entrance panel, key in the number with which you wish to program the internal unit and route the call by pressing button "C".
- 6) At the end of the call signal, lift up the handset, check the audio connection and replace the handset.
- 7) Wait for the LED on the unit to switch off. It should switch off about 5 seconds after the handset is replaced.
- 8) Program the remaining internal units following the same procedure outlined above..

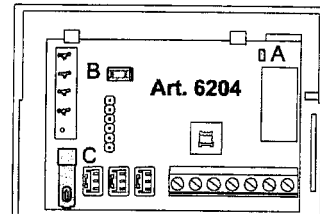

A- LED  
B- Programming button  
C- Lock push-button

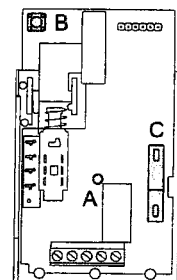



Art. 887B

#### **Programming digital distributors Art. 949B from the entrance panel**



- 1) Briefly press button PS1 on the digital distributor.
- 2) Press then button PS2 on the digital distributor until the first of four LEDs on the distributor illuminates.
- 3) If the LED does not illuminate, repeat the above steps from point 1.
- 4) Remove the handset from the interphone connected to terminals A1 and A3 of the digital distributor in question and check the audio connection with the entrance panel. Replace the handset
- 5) From the entrance panel, key in the number with which you wish to program the internal unit and route the call by pressing button "C".
- 6) At the end of the call signal, lift up the handset, check the audio connection and replace the handset.
- 7) Wait for the LED on the distributor to switch off. It should switch off about 5 seconds after the handset is replaced.
- 8) To program the remaining three interphones connected to the distributor in question, press button PS1 again and hold button PS2 pressed down until the corresponding LED illuminates on the distributor (second, third or fourth LED).
- 9) The LEDs illuminate to indicate which internal unit is currently being programmed as illustrated in the table below, whereby:  
LED 1 ← → Terminals A1 and A3  
LED 2 ← → Terminals B1 and B3  
LED 3 ← → Terminals C1 and C3  
LED 4 ← → Terminals D1 and D3
- 10) Program the remaining internal units following the same procedure outlined above.

#### **PROGRAMMING INTERPHONES AND DIGITAL DISTRIBUTORS FROM SWITCHBOARD Art. 945B AND Art. 955**

To program interphone user numbers with the switchboard, proceed as follows:

- Set the switchboard on "INTERNO" (Internal) mode
- Lift the switchboard handset and press button  so that the indicator lamp in key  illuminates.
- Without replacing the handset on the switchboard, program the interphone or distributor.

#### **Programming interphones with internal coder Art. 6204 and 887B**

- 1) Briefly press the programming button on the interphone.
- 2) Press then the door lock release button  until the LED near the programming button illuminates.
- 3) If the LED does not illuminate, repeat the above steps from point 1.
- 4) Remove the handset from the unit and check the audio connection with the switchboard. Replace the handset on the interphone.
- 5) From the switchboard, key in the number with which you wish to program the internal unit and route the call by pressing button .
- 6) At the end of the call signal, lift up the handset, check the audio connection and replace both handsets.
- 7) Wait for the red LED on the unit to switch off. It should switch off about 5 seconds after the handsets are replaced on the switchboard and interphone.
- 8) Program the remaining internal units following the same procedure outlined above.

**N.B.:** The audio line between the switchboard and interphone is only connected when the led in key  illuminates.

Consequently, if the LED is switched off, press button  again until it illuminates. The LED remains illuminated for the maximum conversation time set for the switchboard.

#### **Programming digital distributors Art. 949B**

- 1) Briefly press button PS1 on the digital distributor.
- 2) Press then button PS2 on the digital distributor until the first of four LEDs on the distributor illuminates.
- 3) If the LED does not illuminate, repeat the above steps from point 1.
- 4) Remove the handset from the interphone connected to terminals A1 and A3 of the digital distributor in question and check the audio connection with the switchboard. Replace the handset on the interphone.
- 5) From the switchboard, key in the number with which you wish to program the internal unit and route the call by pressing button .
- 6) At the end of the call signal, lift up the handset, check the audio connection and replace both handsets.
- 7) Wait for the LED on the distributor to switch off. It should switch off about 5 seconds after the handsets are replaced on the switchboard and interphone.
- 8) To program the remaining three interphones connected to the distributor in question, press button PS1 again and hold button PS2 pressed down until the corresponding LED illuminates on the distributor (second, third or fourth LED).
- 9) The LEDs illuminate to indicate which internal unit is currently being programmed as illustrated in the table below, whereby:  
LED 1 ← → Terminals A1 and A3  
LED 2 ← → Terminals B1 and B3  
LED 3 ← → Terminals C1 and C3  
LED 4 ← → Terminals D1 and D3
- 10) Program the remaining internal units following the same procedure outlined above.

**N.B.:** The audio line between the switchboard and interphone is only connected when the led in key  illuminates.

Consequently, if the LED is switched off, press button  again until it illuminates. The LED remains illuminated for the maximum conversation time set for the switchboard.

### INSTALLATION OPERATION

Standard power supplier Art. 6941/C17 is fitted in DIGIBUS video door entry systems to power the interphones, digital distributors, entrance panels and switchboard. In some installations however, due to particularly long cable runs prone to excessive voltage drops or the number of internal units installed, the following additional power supply units may be installed: Art. 6942 which powers the entrance panels, switchboard, digital distributors and interphones, and Art. 6947 regenerates the call signal. For more information about the layout of power suppliers, refer to the corresponding installation wiring diagrams.

To call interphones from the entrance panel or switchboard, simply key in the user number on the entrance panel or switchboard keypad and press button "C" or  to route the call. To cancel the call, simply press button "R". After the call button has been pressed, the entrance panel or switchboard transmit a digital code which connects the internal unit. The first entrance panel or switchboard connected to the interphone cable riser activates the call generator inside the power supplier for the set call time and routes the call signal to the cable riser. At the end of the call signal, the interphone phonic line connects to the external entrance panel or switchboard.

The auxiliary functions may be activated irrespective of whether the internal unit is activated or not. However, the door lock release button  will only release the entrance panel door lock if the internal unit is connected to the external entrance panel.

Otherwise it will call the porter's switchboard. Once the call has been routed to the internal unit, the two units will only remain connected for the reply delay-time set for the entrance panel or switchboard. If the delay time elapses before the handset is lifted, the entrance panel or switchboard disconnects the internal unit. If instead the handset is lifted within the set reply time, the call is connected and the two units can communicate for the maximum conversation time. If the handset is replaced before the maximum conversation time has elapsed, the interphone is disconnected after about 5 seconds.

### DESCRIPTION OF DIFFERENT INSTALLATIONS

A description follows of three DIGIBUS door entry systems which use power supplier Art. 6941/C17.

If both auxiliary functions are required, terminals F1 and F2 on the entrance panel (or switchboard) must be connected to the corresponding terminals on the power supplier.

If both the auxiliary functions facility are required in installations fitted with interphones Art. 6201, 8877, the corresponding connections must be made between the interphone and digital distributor Art. 949B.

A) Door entry system with one video entrance panel (see drawing p3063 or p3062 on page 11 or 13).

B) Door entry system for building complex (see drawing p2765 on page 17).

C) Door entry system with one entrance panel and switchboard (see drawing pc2769 on page 23).

#### A) Video door entry system with one entrance panel (drawing p3063 or p3062 on page 11 or 13)

- Key in the required user number, (i.e. 77) on the entrance panel keypad.
- Confirm with button "C".
- Terminal +L on the entrance panel activates.
- The digital code corresponding to user number 77 is routed along line 1 to the interphone cable riser.
- The phonic circuit for interphone number 77 connects to the cable riser.
- Entrance panel terminal CH activates for the set call time and routes the call signal along line 3 of the cable riser.
- The entrance panel phonic circuit connects at the end of the call time.
- If the interphone handset is not lifted the entrance panel activates the reply time counter.
- If instead the interphone handset is lifted within the set reply time, the entrance panel activates the maximum conversation time counter.
- The two auxiliary functions and the door lock opening function may all be activated when the handset is lifted or set down. The two auxiliary functions may also be activated when the interphone has not been called.
- When the door lock release button , the door lock release code corresponding to the interphone user number (77) is transmitted by the interphone to the cable riser. The entrance panel from where the call originates then identifies the code and activates terminal S for the set door lock activation time. Power supplier terminal S1 therefore de-energises to zero Volts for the time terminal S is activated.
- When the F2 button is pressed, the code for auxiliary function corresponding to the interphone user number (77) is transmitted by the interphone to the cable riser. The entrance panel then identifies the code and activates terminal F2 for the activation time set for auxiliary function F2.
- When the F1 button is pressed, the code for auxiliary function corresponding to the interphone user number (77) is transmitted by the interphone to the cable riser. The entrance panel then identifies the code and activates terminal F1 for the activation time set for auxiliary function F1.
- Once the reply delay time or maximum conversation time has elapsed, the entrance panel connected to the interphone transmits a reset code to disconnect the interphone.
- The same sequence occurs if the interphone handset is replaced before the maximum conversation time has elapsed. Five seconds after the handset is replaced, the entrance panel transmits a reset code.

#### B) Door entry system for building complex (drawing p2765, page 17)

- Key in the required user number, (i.e. 77) on the main entrance panel keypad.
- Confirm with button "C".
- Terminal +L on the main entrance panel activates.